

Vertical Multistage In-Line



Features & Benefits

The CHC series with suction and discharge connections of the same diameter and arranged along the same axis (in-line). Minimum floor space required and easy to install. High efficiency for energy saving.

Applications

- ▶ Boiler feed
- ▶ Pressure boosting
- ▶ Fire-fighting systems
- ▶ Water systems for industrial uses
- ▶ Water treatment, irrigation & aquaculture

Operation Data

Pump Size	DN 32 up to 200 mm
Capacities	up to 50 l/s
Heads	up to 300 Meter
Speed	2900 rpm
Motor Rating	up to 110 kW
Operating Temperature	up to 120°C*

* The material of pumps differ according to the type of pumped liquid, operating temperature and pressure.

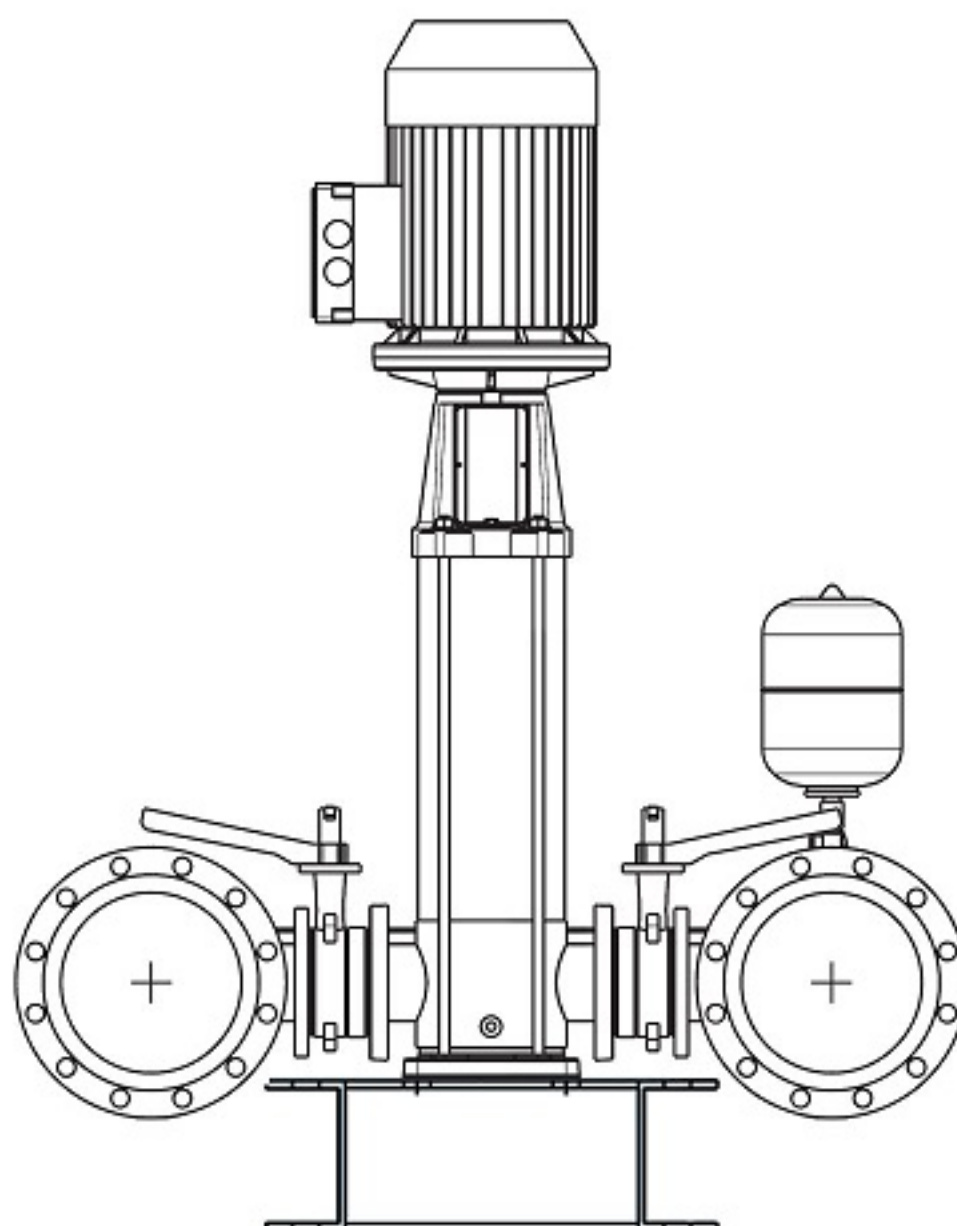

Performance Range

